



FrontLoad bill validator

features

- Fixed-width or multi-width bill and coupon validation (62mm-82mm wide).
- Flexible *Sense-a-Click™* sensor paks.
- Patented advanced sensor technology improves valid bill recognition & protects against counterfeits.
- Quick and easy Smart-Stick memory software updates.
- Single-stacking cassettes reduce jamming.
- Optional self-centering transport guides perfectly align multi-width and/or skewed bills.
- Tool-free, one-step, easy service access.
- Beltless transport system.
- Anti-stringing protection.
- Four-way bill validation.

CASHCODE'S FRONTLOAD BILL VALIDATOR. THE MOST FLEXIBLE AND TECHNOLOGICALLY ADVANCED CURRENCY VALIDATOR EVER DESIGNED FOR HIGH-SECURITY, FRONT-LOADING INSTALLATIONS.

Fixed-width or multi-width. It's up to you. Choose between *fixed-width* validation, or the flexibility of our *multi-width* option—the perfect solution for *multi-country* currency validation, 62-82mm wide. Unlike competitive products that use graduated bill paths, the multi-width FrontLoad bill validator uses patented *self-centering transport guides* that automatically adjust to, and perfectly align bills or barcoded coupons of different widths—even when fed at an angle.

Sense-a-Click™ sensor paks. Patented *Sense-a-Click™* sensor paks provide easy adjustment and versatility for recognizing a diverse range of currencies. Simply “click” in the sensor paks and you're ready to go.

Advanced sensor technology. Proprietary *multi-color optic* sensors inside *Sense-a-Click™* modules scan both sides of the bill—optimizing recognition. Patented *inductive* sensors detect magnetic properties inherent in legitimate currency. A patented *dielectric* sensor detects paper density, security threads and watermarks. *The result?* The highest security in the industry.

Smart-Stick memory. Validation software updates are now quick and easy with Smart-Stick memory that updates software in a flash.

Single-stacking cassettes. CashCode's lockable-removable cassettes stack bills without moving the stack mass—eliminating bowing and jamming, reducing power consumption and creating more stacking capacity.

Triple the security. Keep your cash secure with two optional cassette locks and a patented third lock built into the validator frame.

Verify your count. Equip your cassette with an optional Dallas Semiconductor iButton® and get an instant verification of every transaction made by the cassette, including total intake, denomination breakdown and any change in the validation rate.



INSTRUMENTS & EQUIPMENT COMPANY
2 Wilson Drive, Sparta, NJ 07871
Tel: 800-432-1255 Fax: 973-579-6665
email: ieoem@ieoem.com web: www.ieoem.com

FrontLoad bill validator

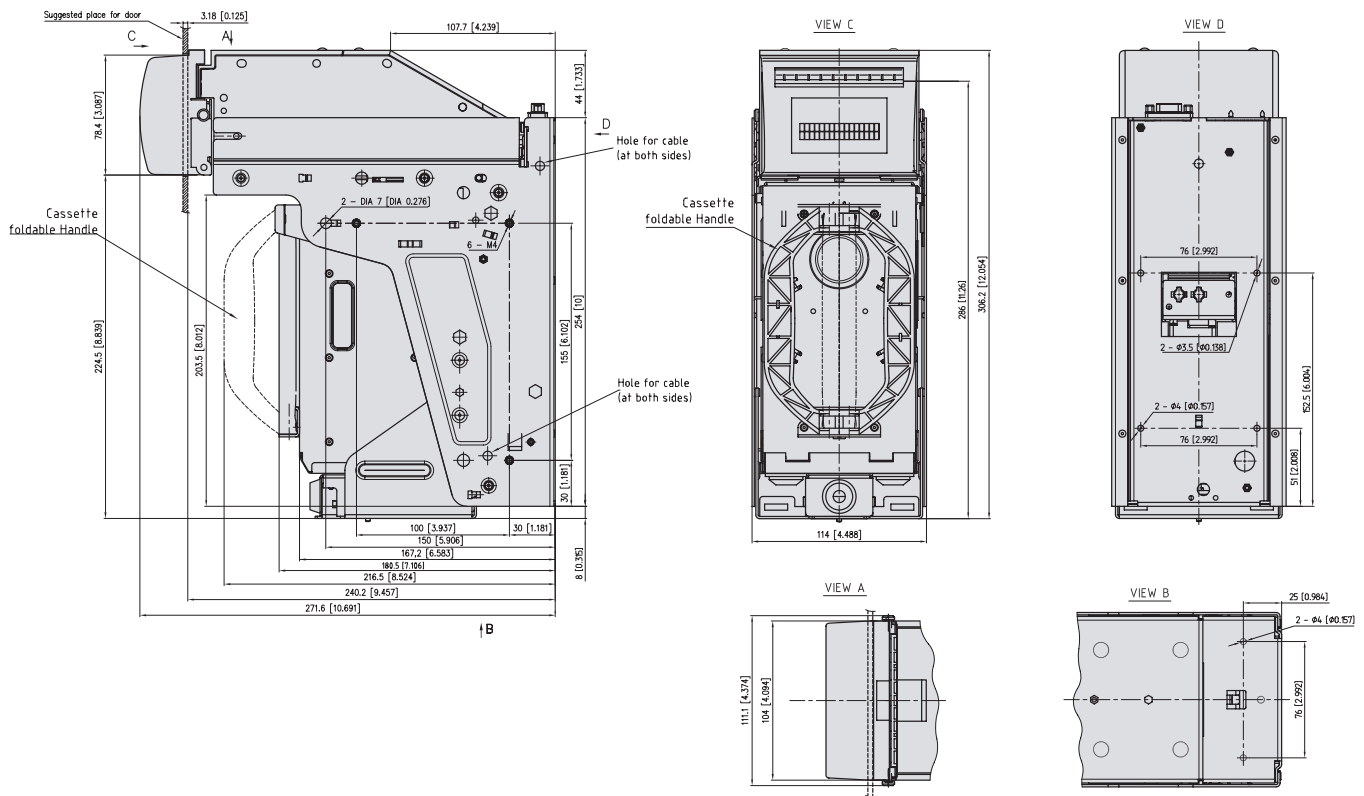

specifications

Bill Width Validated	67 or 71mm wide (fixed-width) 62 to 82mm wide (multi-width)
Bill Insertion	Four-way
Validation Rate	96% or higher
Escrow	One bill
Sensors	Patented optical, inductive, dielectric and cross-channel (anti-stringing)
Bezel Options	1) standard; 2) LED; 3) LED w/ digital display; 4) LED w/ digital display and smart card
Interfaces Supported	Bi-directional (RS232), serial, pulse, opto-isolated
Protocols Supported	CCNET, CashCode serial, and most other industry standard protocols supported.
Program Memory	Smart-Stick memory or downloadable
Operating Voltage	12V DC: 2.0 A or 24V DC: 1.0 A
Operating Temperature	0° C to 50° C
Validation M.T.B.F.	1.2 million cycles
Complete Transport Cycle	3.5 sec / 4.5 sec (multi-width)
Dimensions (W x H x D)	114 x 317 x 230 mm
Weight	< 4.2 kg
Cassette Sizes Available	600 or 1000 capacity
Cassette Options	Up to three custom locks; DS iButton® memory
Approvals	CSA approved



Sense-a-Click™ sensor paks provide an easy adjustment for country-specific currency updates or changes.



CashCode's Smart-Stick memory makes validation software updates quick and easy.



Bezel options allow for the flexibility to accept bills as well as cashless currency like smart cards.



Our modular design gives you the choice of interfaces, cassettes, locks, sensors and multi-width capability.



Optional self-centering guides automatically adjust to and align multi-width currency 62-82mm wide.



Single-stacking cassettes reduce jamming and power consumption. 600 or 1000 bill capacity available.